

INSERT DIN POUR SURMOULAGE - SÉRIE 16903

APPLICATION

Insert selon la norme DIN 16903 pour une utilisation en surmoulage dans les matières plastiques. Toutes les variantes de dimensions sont possibles à la demande.



SÉRIE 16903 - FORME A

Filetage	S	d3	L1
M3	5	3.8	3
M4	6	5	4
M5	7	6.4	5
M6	9	7.4	6
M8	11	10.4	8

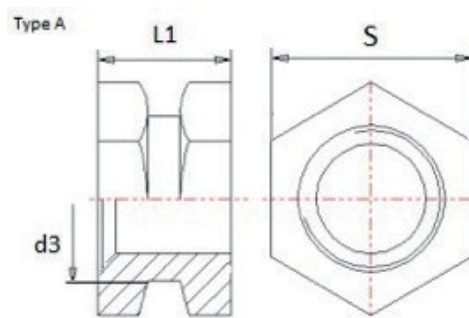

SÉRIE 16903 - FORME B

Filetage	d5	d3	L1
M2.5	3.8	3.4	2.6
M3	4.2	3.8	3
M4	5.5	5	4
M5	7	6.4	5
M6	8	7.4	6

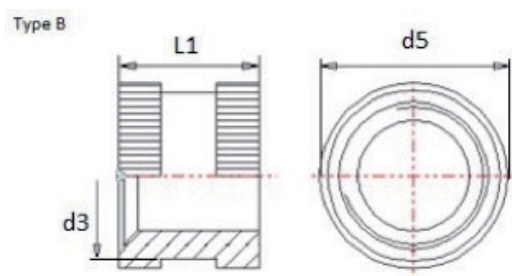

SÉRIE 16903 - FORME C

Filetage	S	d3	b2	L2	d6
M3	5	3.8	1	4.5	4.2
M4	6	5	1	6	5.5
M5	7	6.4	1	7.5	7
M6	9	7.4	1	9	8
M8	11	10.4	1	12	10

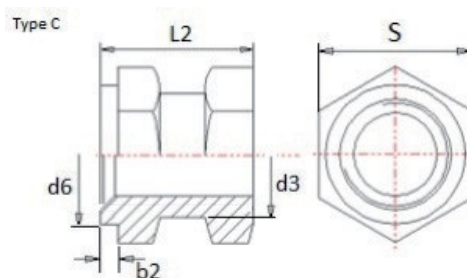

SÉRIE 16903 - FORME D

Filetage	d5	d3	b2	L2	d6
M2.5	3.8	3.4	0.8	4	3.8
M3	4.2	3.8	1	4.5	4.2
M4	5.5	5	1	6	5.5
M5	7	6.4	1	7.5	7
M6	8	7.4	1	9	8

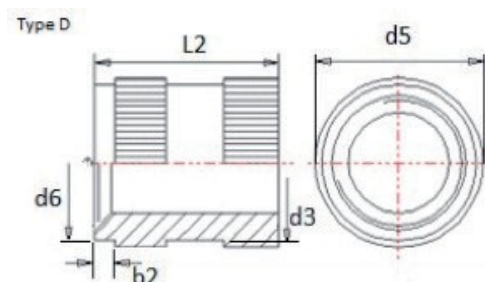

SÉRIE 16903 - FORME P

Filetage	S	d3	L1	L3
M3	5	3.8	3	5.5
M4	6	5	4	7
M5	7	6.4	5	8.3
M6	9	7.4	6	9.8
M8	11	10.4	8	12.6

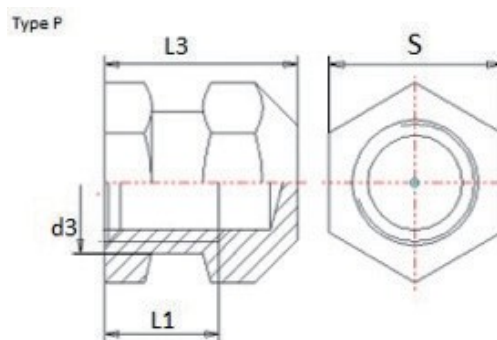

SÉRIE 16903 - FORME Q

Filetage	d5	d3	L1	L3
M2.5	3.8	3.4	2.6	4.6
M3	4.2	3.8	3	5.5
M4	5.5	5	4	7
M5	7	6.4	5	8.3
M6	8	7.4	6	9.8

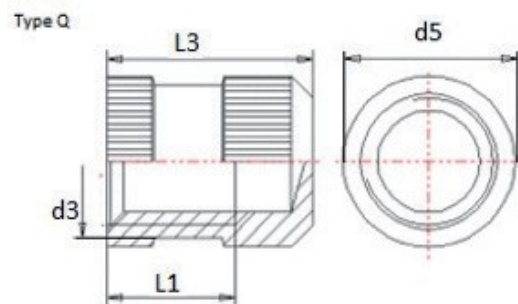

SÉRIE 16903 - FORME R

Filetage	S	d6	b2	L2	L4
M3	5	4.2	1	4.5	7
M4	6	5.5	1	6	9
M5	7	7	1	7.5	10.8
M6	9	8	1	9	12.8
M8	11	10	1	12	16.6

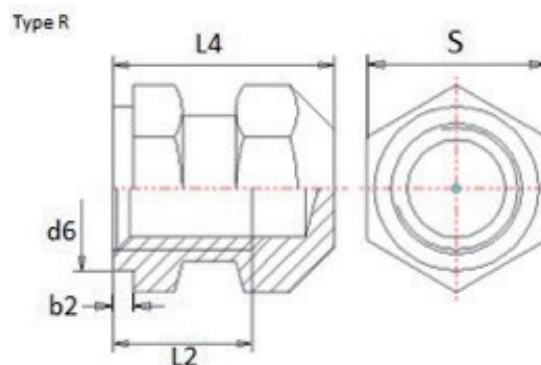

SÉRIE 16903 - FORME S

Filetage	d5	d6	b2	L2	L4
M2.5	3.8	3.8	0.8	4	6
M3	4.2	4.2	1	4.5	7
M4	5.5	5.5	1	6	9
M5	7	7	1	7.5	10.8
M6	8	8	1	9	12.8

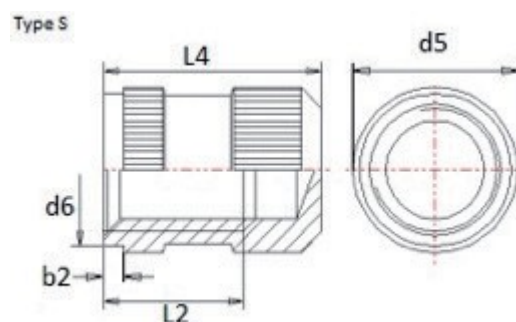

MATIÈRES ET FINITIONS

- Laiton en standard
- Autre matières et finitions sur demande
- Brute, Nickelée
- Zinguée