

# DIN INSERTS FOR OVERMOULDING – SERIES 16903

## APPLICATION

Insert to DIN 16903 standard for overmoulding use in plastics. All size variations are possible on request.

\*\*Outside diameter before knurling



## SERIES 16903 – TYPE A

| Thread | S  | d3   | L1 |
|--------|----|------|----|
| M3     | 5  | 3.8  | 3  |
| M4     | 6  | 5    | 4  |
| M5     | 7  | 6.4  | 5  |
| M6     | 9  | 7.4  | 6  |
| M8     | 11 | 10.4 | 8  |

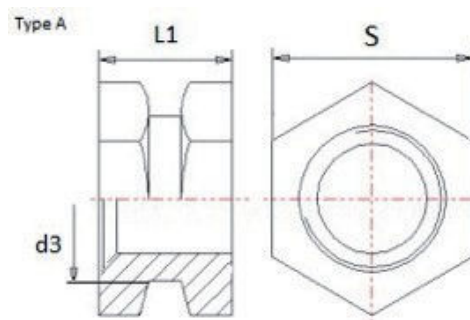

## SERIES 16903 – TYPE B\*\*

| Thread | d5  | d3  | L1  |
|--------|-----|-----|-----|
| M2.5   | 3.8 | 3.4 | 2.6 |
| M3     | 4.2 | 3.8 | 3   |
| M4     | 5.5 | 5   | 4   |
| M5     | 7   | 6.4 | 5   |
| M6     | 8   | 7.4 | 6   |

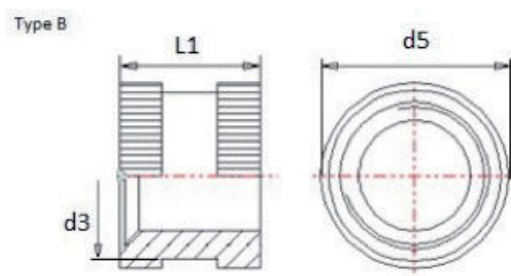

## SERIES 16903 – TYPE C

| Thread | S  | d3   | b2 | L2  | d6  |
|--------|----|------|----|-----|-----|
| M3     | 5  | 3.8  | 1  | 4.5 | 4.2 |
| M4     | 6  | 5    | 1  | 6   | 5.5 |
| M5     | 7  | 6.4  | 1  | 7.5 | 7   |
| M6     | 9  | 7.4  | 1  | 9   | 8   |
| M8     | 11 | 10.4 | 1  | 12  | 10  |

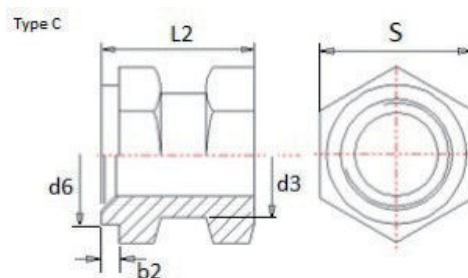

## SERIES 16903 – TYPE D\*\*

| Thread | d5  | d3  | b2  | L2  | d6  |
|--------|-----|-----|-----|-----|-----|
| M2.5   | 3.8 | 3.4 | 0.8 | 4   | 3.8 |
| M3     | 4.2 | 3.8 | 1   | 4.5 | 4.2 |
| M4     | 5.5 | 5   | 1   | 6   | 5.5 |
| M5     | 7   | 6.4 | 1   | 7.5 | 7   |
| M6     | 8   | 7.4 | 1   | 9   | 8   |

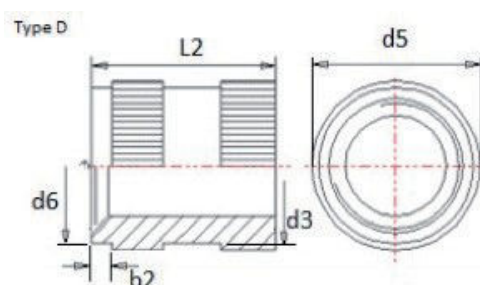

**SERIES 16903 – TYPE P**

| Thread | S  | d3   | L1 | L3   |
|--------|----|------|----|------|
| M3     | 5  | 3.8  | 3  | 5.5  |
| M4     | 6  | 5    | 4  | 7    |
| M5     | 7  | 6.4  | 5  | 8.3  |
| M6     | 9  | 7.4  | 6  | 9.8  |
| M8     | 11 | 10.4 | 8  | 12.6 |

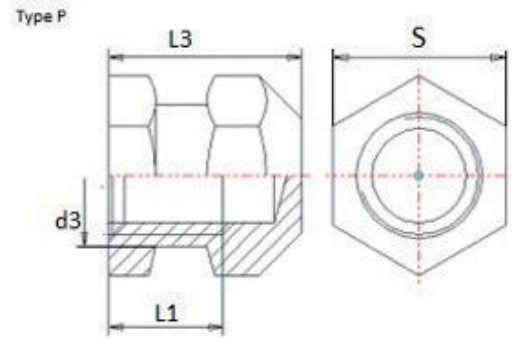

**SERIES 16903 – TYPE Q\*\***

| Thread | d5  | d3  | L1  | L3  |
|--------|-----|-----|-----|-----|
| M2.5   | 3.8 | 3.4 | 2.6 | 4.6 |
| M3     | 4.2 | 3.8 | 3   | 5.5 |
| M4     | 5.5 | 5   | 4   | 7   |
| M5     | 7   | 6.4 | 5   | 8.3 |
| M6     | 8   | 7.4 | 6   | 9.8 |

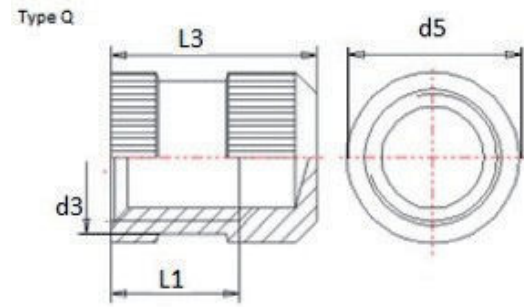

**SERIES 16903 - TYPE R**

| Thread | S  | d6  | b2 | L2  | L4   |
|--------|----|-----|----|-----|------|
| M3     | 5  | 4.2 | 1  | 4.5 | 7    |
| M4     | 6  | 5.5 | 1  | 6   | 9    |
| M5     | 7  | 7   | 1  | 7.5 | 10.8 |
| M6     | 9  | 8   | 1  | 9   | 12.8 |
| M8     | 11 | 10  | 1  | 12  | 16.6 |

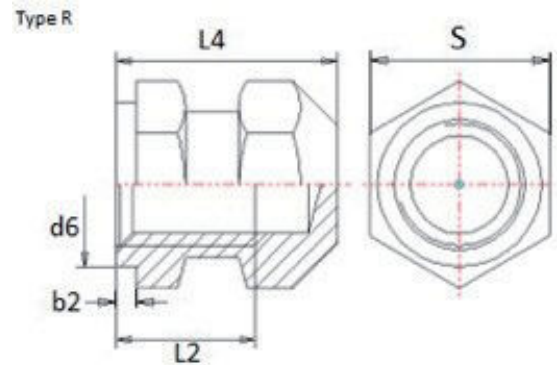

**SERIES 16903 – TYPE S\*\***

| Thread | d5  | d6  | b2  | L2  | L4   |
|--------|-----|-----|-----|-----|------|
| M2.5   | 3.8 | 3.8 | 0.8 | 4   | 6    |
| M3     | 4.2 | 4.2 | 1   | 4.5 | 7    |
| M4     | 5.5 | 5.5 | 1   | 6   | 9    |
| M5     | 7   | 7   | 1   | 7.5 | 10.8 |
| M6     | 8   | 8   | 1   | 9   | 12.8 |

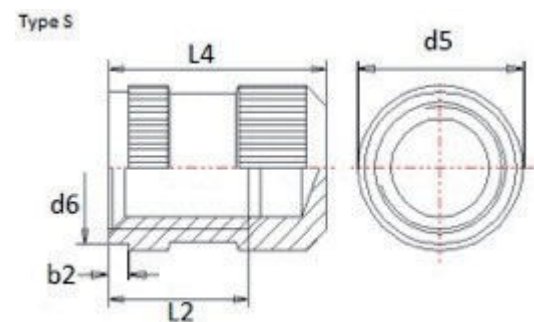

**MATERIALS AND FINISH**

- Brass as standard
- Other materials and finishes on request
- Plain
- Nicked-plated